

Click on a link
tab to jump to
that page

Cover
Page

Before
You Begin

Remove
& Install

Wire
New Radio

Mount
New Radio

Publication, Duplication, or Retransmission Of This Document Not Expressly Authorized In Writing By The Install Doctor Is Prohibited. Protected By U.S. Copyright Laws. © 1997,1998,1999,2000.

Factory Radio



New Radio and radio installation kit



Other Documents Available For This Vehicle:

No documents available at this time

Adobe Acrobat Reader Printing Tips:

- 1) Select "**FILE**" then "**PRINT**" and select your printer.
- 2) In the print options box do the following:
 - A) Locate check box "**Shrink to Fit**". Place check in box.
 - B) Locate box "**Print Quality**". Select highest print dpi allowed by printer.
 - C) If print quality listed is not as high as that printers normal quality, press the "**SETUP..**" button. In the next screen, press the "**PROPERTIES**" button and set the printers print quality to the highest print dpi allowed.

Document Revision History

09/99 Document Creation
12/99 Photo Update

Click on a link
tab to jump to
that page

Cover
Page

Before
You Begin

Remove
& Install

Wire
New Radio

Mount
New Radio

Publication, Duplication, or Retransmission Of This Document Not Expressly Authorized In Writing By The Install Doctor Is Prohibited. Protected By U.S. Copyright Laws. © 1997,1998,1999,2000.

Overview Of This Radio Install

Step	What Section To Go To
Remove old radio from dash	Remove & Install
Wire the new radio	Wire New Radio
Mount the new radio	Mount New Radio
Finishing the installation	Remove & Install

Parts Needed For This Radio Install

Parts REQUIRED for the install	Description
Snap on in dash wire harness	Honda 99 and newer harness
Radio dash installation kit	Honda "multi" kit

Optional parts for this install

None

Tools Needed To Complete This Install

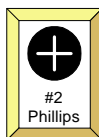

#2
Phillips

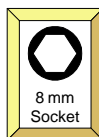

8 mm
Socket

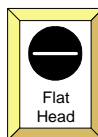

Flat
Head



Solder/
Crimper

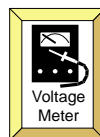

Voltage
Meter

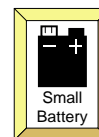

Small
Battery



TOOL TIPS:

Small Battery: use a battery to test speaker wires. Touching the (+) positive and (-) negative battery leads to a pair of speaker will cause the speaker to make a "Pop" sound indicating that pair of wires goes to that speaker.
Voltage Meter: Always check +12 Volt power wires for voltage before making wire connections. These wires will fluctuate between 10 and 14 Volts.
Solder Iron or Crimp Tool: make wire to wire connections using either a solder iron and electrical tape, OR plastic crimp terminals found at most hardware or auto parts stores.

Hand tools needed
to remove radio

Accessory tools needed to test and
wire the new radio

PLUS: Wire ties or electrical tape: to neatly bundle and organize your wires for a professional appearance.

Installation Difficulty Ratings

Easy. No advanced skills or specialty tools needed.

Basics. Simple tools required. Installs quickly.

Intermediate. Requires knowledge of tools, or disassembly of panels.

Advanced. Requires advanced tools, or extra time.

Difficult. Involves modifying or cutting of the installation area. Advanced tools and/or skills required. Best if performed by experienced installers.

Do It Yourselfers

Advanced

Professional Installer

Intermediate

Support Information If You Need Help

Supplemental information if you need help

Document Title	Document #
Basic DC electronics for automotive applications	999001
Wire splicing: soldering vs. crimping	999004
Why use radio installation kits	999005
Mounting your radio to an installation kit	999007
Why use an optional snap on wire harness	999008
Wiring your new radio using a wire harness	999009
Testing wires when installing a new radio	999013

► Remove Factory Radio



STEP 1:

Removing the radio in this vehicle requires removing lower dash panels on both the drivers and passenger sides of the vehicle. The radio is actually secured to the center dash panel as one unit along with the air conditioner vents, air conditioner controls, hazard switch, and defrost buttons. Once the center dash unit is removed, the radio can then be separated from the dash unit.

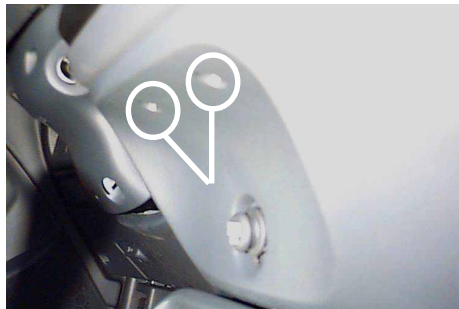

STEP 2:

Locate and remove **(2) phillips screws** on the curved lower dash panel below the radio. The 2 screws will be located above the cigarette lighter plug.



STEP 3:

Open the glove box. There are two (2) hidden screws that need to be removed.

The first screw is located at the top left corner of the glove box assembly. Locate and remove one (1) **brass colored phillips screw**.

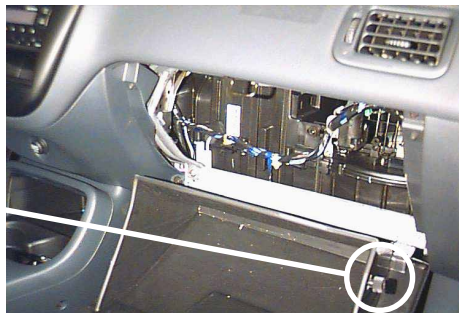

STEP 4:

The glove box must be freed from the dash. To keep the glove box from falling to the floor of the vehicle, stop bumpers are attached to each side of the glove box. With you hand, firmly push in the thin plastic of the glove box. You will see the stop bumper attached to the side of the glove box. If you push in hard enough, you can free the stop bumper from behind the dash. Do this to each side, one side at a time, and the glove box will fall free of the dash panel.

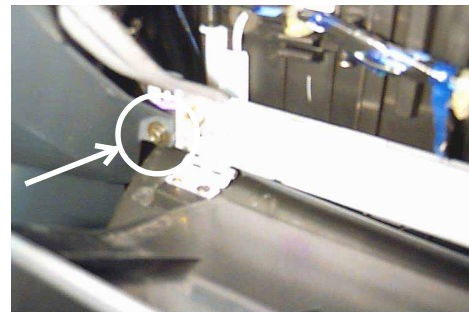

STEP 5:

The second hidden screw is located at the lower left corner of the glove box and can only be accessed when the glove box is completely lowered out of the dash. This screw is a phillips screw as well as an 8 mm bolt. Remove this screw/bolt.

Radio Replacement

Document #: 466005

Click on a link
tab to jump to
that page

Cover
Page

Before
You Begin

Remove
& Install

Wire
New Radio

Mount
New Radio

Publication, Duplication, or Retransmission Of This Document Not Expressly Authorized In Writing By The Install Doctor Is Prohibited. Protected By U.S. Copyright Laws. © 1997,1998,1999,2000.

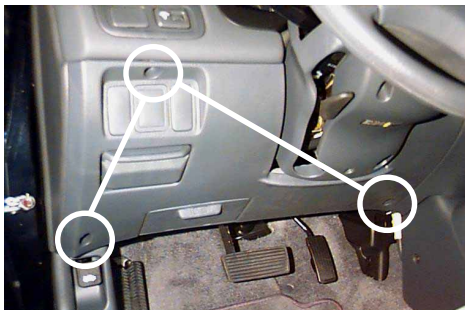

STEP 6:

You will need to remove the lower left dash panel below the steering column. This panel is secured to the main dash with three **(3) phillips screws**. Remove all 3 phillips screws.

STEP 7:

Once all 3 phillips screws have been remove, the lower dash panel can be pulled from the main dash. The top of the lower dash panel is secured to the main dash with one snap on the left of the steering column, and one snap on the right of the steering column. Gently pull to unsnap and free the lower dash panel from the main dash.



STEP 8:

Once the lower left dash panel has been removed, you will be able to see a brass colored screw that had been hidden behind the top right of the dash panel just removed (to the right of the steering column). Locate and remove one **(1) phillips screw**.

Radio Replacement

Document #: 466005

 Click on a link
tab to jump to
that page
Cover
PageBefore
You BeginRemove
& InstallWire
New RadioMount
New Radio

Publication, Duplication, or Retransmission Of This Document Not Expressly Authorized In Writing By The Install Doctor Is Prohibited. Protected By U.S. Copyright Laws. © 1997,1998,1999,2000.

**STEP 9:**

All hidden screws securing the lower center dash panel have been removed. With your hands, pull the right side of the lower dash panel (the part of the panel secured by 2 screws hidden behind the glove box) then pull the left side. You will have to wiggle the panel but should be able to pull the panel clear away from the main dash.

**STEP 10:**

Unplug the connector attached to the rear of the cigarette lighter attached to the lower dash panel.

Once the lower dash panel is removed, you should be able to see metal brackets and wires located below the radio assembly.

**STEP 11:**

Look up at the bottom of the radio from the drivers side of the vehicle. You will see a silver colored metal bracket located below the radio. You should see four (4) brass colored phillips screw / 8mm bolts screwed into the plate. Remove all 4 phillips screw / 8mm bolts.

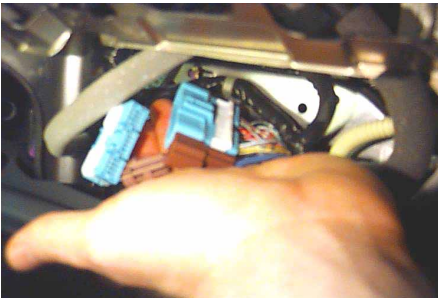
**STEP 12:**

Removing the 4 screw/bolts in the previous step will allow you to remove the radio from the dash. But, the wiring attached to the rear of the radio is secured with clips to the frame of the dash. Because of these clips the radio will resist pulling from the dash. However, there is a work around. You can free the radio by unplugging the Brown and Lite Blue connectors located below the radio (they are located behind the area where the cigarette lighter would normally be). Once these two connectors have been unplugged from their mating connectors inside the dash, the entire radio dash assembly should be able to be pulled from the dash.

Note: The radio is difficult to remove even with all the wiring disconnected. You may have to reach underneath the radio and push the dash assembly from the rear to get it started. Be careful of the metal brackets below the radio, the edges may be sharp.

**STEP 13:**

When the radio dash assembly is pulled out about 4 inches, you will see a white connector plugged into the rear of the hazard switch. Unplug the white connector (the tab to push in to unplug the connector is located on the bottom of the connector).

Unplug any other connector attached to the radio dash assembly so you can completely remove the radio dash assembly from the vehicle.

Click on a link
tab to jump to
that page

Cover
Page

Before
You Begin

Remove
& Install

Wire
New Radio

Mount
New Radio

Publication, Duplication, or Retransmission Of This Document Not Expressly Authorized In Writing By The Install Doctor Is Prohibited. Protected By U.S. Copyright Laws. © 1997,1998,1999,2000.

▶ Remove Radio From Dash Assembly

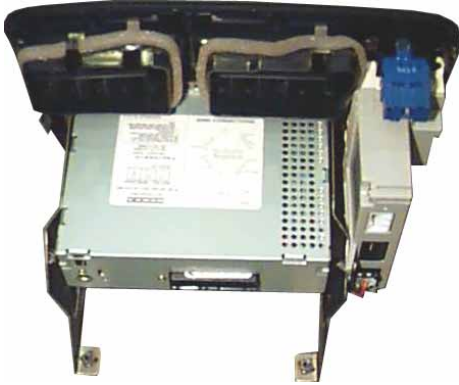

STEP 14:

The removed radio dash assembly should look like the photo above. Notice the metal brackets attached to each side of the radio. These brackets must NOT be removed. These brackets actually secure the radio dash assembly to the dash (the 4 screw/bolts you removed below the radio in an earlier step). There are 4 phillips screws / 8mm bolts that secure the radio and pocket below the radio to these metal brackets. The following steps show you how to do this.

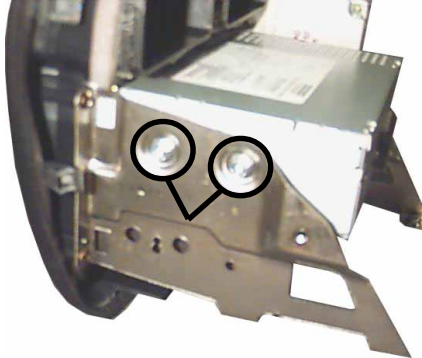

STEP 15:

On the open side of the radio dash assembly, remove two (2) **phillips screws / 8mm bolts** that secure the side of the radio to the metal bracket.

The screws/bolts securing the opposite side are hidden behind a gray control box. The following steps show you how to get access to these screws/bolts.

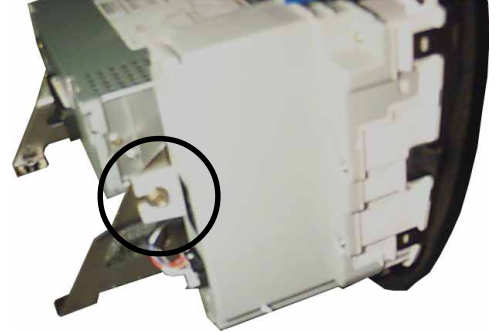

STEP 16:

The rear of the gray control box is secured to the metal bracket with one (1) 8mm bolt. Remove the bolt.



STEP 17:

The top of the gray control box is secured with two (2) **black phillips screws**. Remove both phillips screws. One is hidden in the photo above - it is located between the gray control box and the side of the radio.

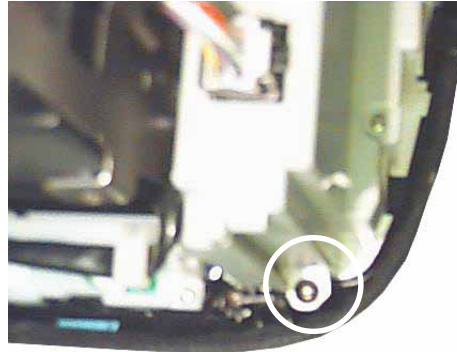

STEP 18:

The bottom of the gray control box is secured with one (1) **black phillips screw**. Remove the phillips screw.

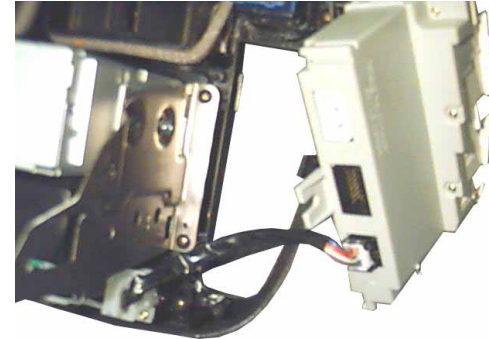

STEP 19:

Once all 3 screws securing the gray control box have been removed, pull it to separate it from the radio dash assembly. You do NOT need to unplug the connector attached to the gray control box.

You now have access to the two (2) **phillips screw / 8mm bolts** securing this side of the radio to the metal bracket. Remove both screws/bolts.

▶ Wiring The New Radio

Move to: [Wire New Radio Section](#)

▶ Mounting The Radio

Move to: [Mounting New Radio Section](#)

▶ Completing The Radio Installation



STEP 1:

Once the auto makers radio is removed, you can snap the plastic radio installation kit into the opening of the dash. Once the kit is snapped into to radio dash assembly, the radio can then be mounted to the kit.

Installation Tip: It is best to attached the radio installation kit into the radio dash assembly before mounting the new radio to the kit. It may be hard for the radio installation kit to properly attach to the radio dash assembly if the radio is already mounted to the kit.



STEP 2:

Insert the radio/dash assembly back into the opening in the dash. Reconnect all wire connectors to the air conditioner controls connected to the dash assembly.

Plug the black antenna cable into the rear of the new radio. Make sure all wire connections to the new radio have been completed and plug any connectors to the new radio into the rear fo the new radio now.

Push the dash assembly back into the dash until the snaps of the plastic dash assembly snap firmly into the surround dash opening.

**** Secure the lower part of the dash with the 8 mm bolts that were removed earlier. ****

Publication, Duplication, or Retransmission Of This Document Not Expressly Authorized In Writing By The Install Doctor Is Prohibited. Protected By U.S. Copyright Laws. © 1997,1998,1999,2000.

Step By Step Wiring

Page 1 of 2

Auto Makers
Factory
Radio

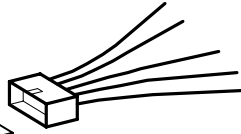
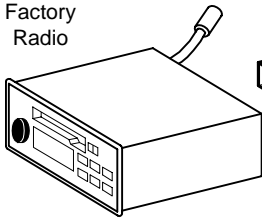

Wire Harness Inside Vehicles
Dash Which Plugs Into The
Rear Of The Factory Radio

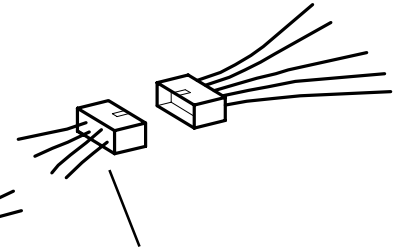
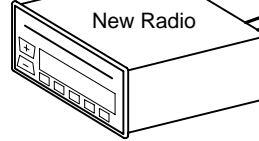

Optional (STRONGLY
RECOMMENDED) Snap On Wire
Harness That Splices Into The
Wires Of The New Radio

(Note: the radio shown is for display purposes and may not be similar in size or dimensions than the auto makers factory radio in your vehicle)

Supplemental information if you need help

Document Title	Document #
Testing wires when installing a new radio	999013
Why use an OEM snap on wire harness	999008
Wiring your new radio using a wire harness	999009
Wire splicing: soldering vs. crimping	999004

Wiring Instructions:

The power and speaker wires needed to connect the new radio are attached to the connector of the wire harness located inside the vehicles dash. The Install Doctor **STRONGLY** recommends using an optional snap on wire harness that is specifically designed to snap into the vehicles dash wire harness connector. This will keep you from cutting the vehicles wires. This optional snap on wire harness will have wires on the opposite side of the connector that will allow you to splice these wires to the new radios wires. The only other option is to cut off the vehicles dash wire harness connector and splice the new radios wires directly to these wires. The optional snap on wire harness takes all the guess work out of trying to figure out what each wire is in the vehicles dash wire harness. The optional snap on wire harness shows you what each wire is.

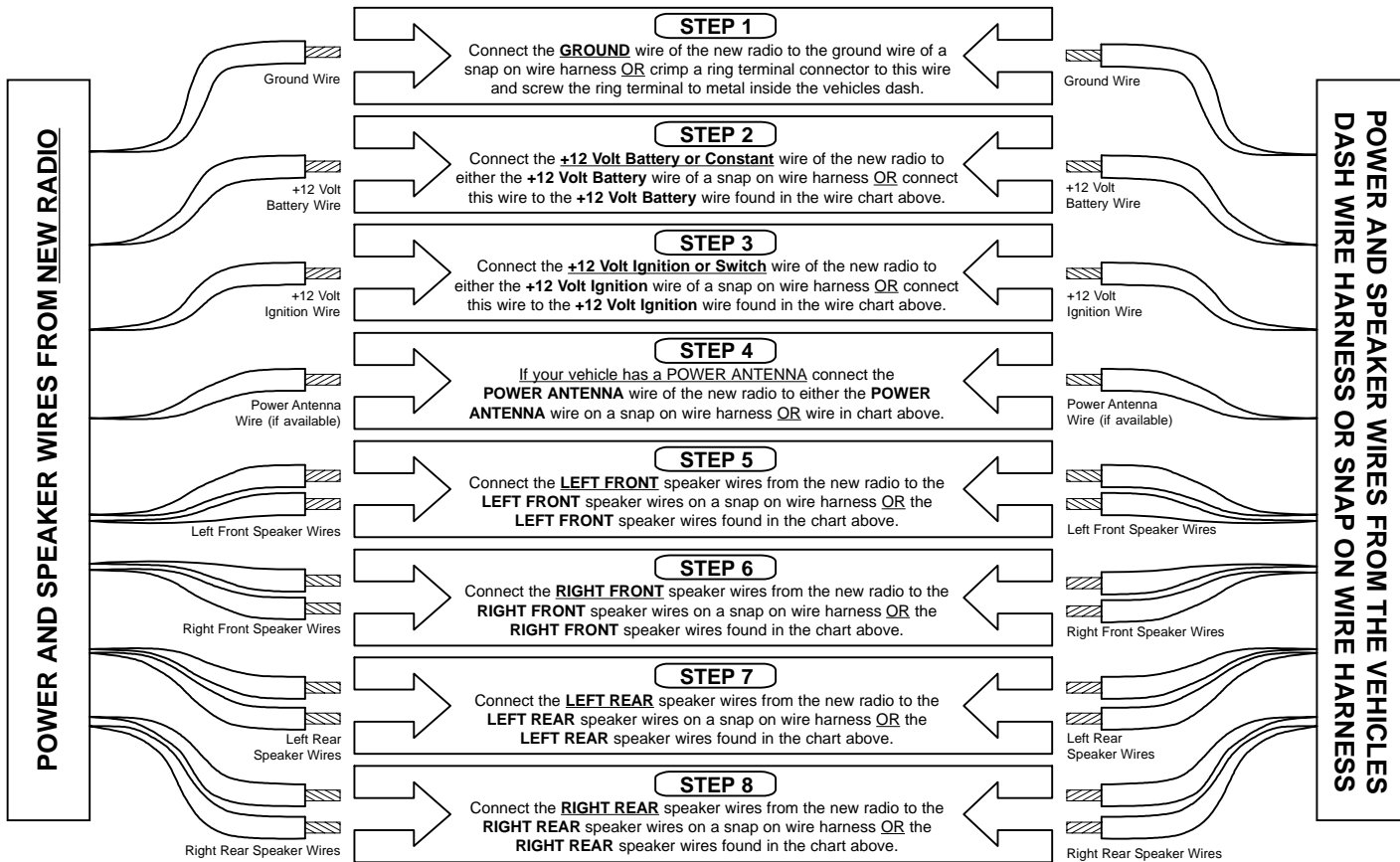

Click on a link
tab to jump to
that page

Cover
Page

Before
You Begin

Remove
& Install

Wire
New Radio

Mount
New Radio

Publication, Duplication, or Retransmission Of This Document Not Expressly Authorized In Writing By The Install Doctor Is Prohibited. Protected By U.S. Copyright Laws. © 1997,1998,1999,2000.

▶ Radio Wire & Color Code Information

Factory in-dash wire harness that snaps into the factory radio.

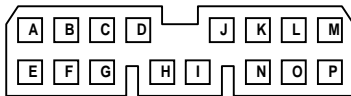

AS VIEWED FROM MATING END OF CONNECTOR

Honda & Acura Wire Harnesses Up To 1997-1998 Production Models

Pin	What It Is	Typical Honda/Acura In Dash Wire Color	"Typical" New Radio Equivalent Wire Color
A	Right Rear Spkr (+)	Red w/ Yellow Stripe	Purple
B	Left Rear Spkr (+)	Blue w/ Yellow Stripe	Green
C	Power Antenna Trigger	Brown w/ White Stripe	Blue or Blue w/ Wht Stripe
D	+12 Volt Ignition Wire	Yellow w/ Red Stripe	Red
E	Right Rear Spkr (-)	Brown w/ White Stripe	Purple w/ Black Stripe
F	Left Rear Spkr (-)	Gray w/ White Stripe	Green w/ Black Stripe
G	Ground Wire	Black	Black
H		Do Not Use	
I		Do Not Use	
J	+12 Volt Battery Wire	White w/ Yellow or Blu Stripe	Yellow
K	Dash Light Dimmer Wire		Orange
L	Left Front Spkr (+)	Blue w/ Green Stripe	White
M	Right Front Spkr (+)	Red w/ Green Stripe	Gray
N		Do Not Use	
O	Left Front Spkr (-)	Gray w/ Black Stripe	White w/ Black Stripe
P	Right Front Spkr (-)	Brown w/ Black Stripe	Gray w/ Black Stripe

Note: using an optional snap on wire harness adapter will simplify the wiring. Most snap on wire harness adapters have already converted and color coded the wires from the auto makers in dash wire harness to match typical aftermarket radio wire colors.

** The wire colors listed in the chart above are typical for these vehicles during these years but may not be the exact colors for this vehicle. This is another reason to use a snap on wire harness adapter. **

Factory in-dash wire harness that snaps into the factory radio.

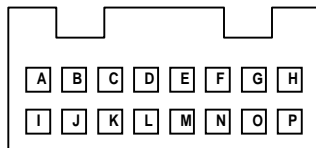

AS VIEWED FROM MATING END OF CONNECTOR

Honda & Acura Wire Harnesses 1998-1999 And Newer Production Models

Pin	What It Is	Typical Honda/Acura In Dash Wire Color	"Typical" New Radio Equivalent Wire Color
A	Right Front Spkr (-)	Brown w/ Black Stripe	Gray w/ Black Stripe
B	Right Front Spkr (+)	Red w/ Green Stripe	Gray
C	Right Rear Spkr (-)	Brown w/ White Stripe	Purple w/ Black Stripe
D	Right Rear Spkr (+)	Red w/ Yellow Stripe	Purple
E		Do Not Use	
F		Do Not Use	
G		Do Not Use	
H	Dash Light Dimmer Wire		Orange
I	Honda Amp Ground Wire		
J	Left Front Spkr (-)	Gray w/ Black Stripe	White w/ Black Stripe
K	Left Front Spkr (+)	Blue w/ Green Stripe	White
L	Left Rear Spkr (-)	Gray w/ White Stripe	Green w/ Black Stripe
M	Left Rear Spkr (+)	Blue w/ Yellow Stripe	Green w/ Black Stripe
N	Ground Wire	Black	Black
O	+12 Volt Ignition Wire	Yellow w/ Red Stripe	Red
P	+12 Volt Battery Wire	White w/ Yellow Stripe	Yellow

Note: using an optional snap on wire harness adapter will simplify the wiring. Most snap on wire harness adapters have already converted and color coded the wires from the auto makers in dash wire harness to match typical aftermarket radio wire colors.

** The wire colors listed in the chart above are typical for these vehicles during these years but may not be the exact colors for this vehicle. This is another reason to use a snap on wire harness adapter. **

Radio Replacement

Document #: 466005

Click on a link
tab to jump to
that page

Cover
Page

Before
You Begin

Remove
& Install

Wire
New Radio

Mount
New Radio

Publication, Duplication, or Retransmission Of This Document Not Expressly Authorized In Writing By The Install Doctor Is Prohibited. Protected By U.S. Copyright Laws. © 1997,1998,1999,2000.

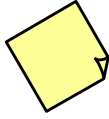

NOTE:

Before you begin: The best metho

All information needed to complete the mounting of the new radio to the installation kit is included on this sheet. If you need additional help, please consult the following tech documents:

Document Title	Document #
Why use radio installation kits	999005
Mounting your radio to an installation kit	999007
Radio security	999010

Honda/Acura Radio
Installation Kit

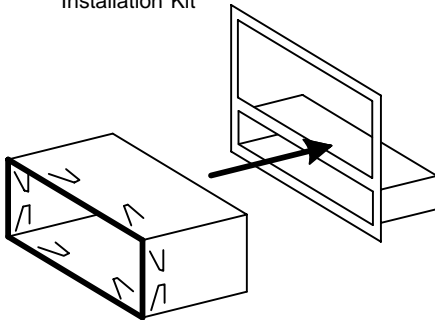

'DIN' Sleeve From New
Replacement Radio

Slide The 'DIN' Sleeve From The New Radio Into The Kit And Bend Tabs On The Sleeve Behind The Rear Of The Kit To Secure The Sleeve To The Kit.

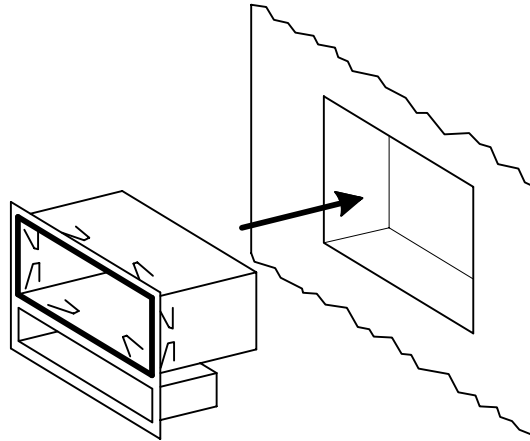

Push The Kit Into The Dash Opening. Depending Upon The Kit Design, The Kit Should Secure To The Dash By Snapping Into The Opening.